

## GRAND AMERICAN MODIFIED RULES

High Banks Speedway Reserves the right to alter or amend the Rules and Regulations in the interest of safety, cost control, and / or fair competition.

### GRAND AMERICAN MODIFIED TEMPLATE INSTALLATION GUIDELINES

Letter	Max.	Min.
A.	NO MAX	108"
B.	38"	28"
C.	48"	34"
D.	Body cannot go further forward than rear of engine block	
E.	72" Or Past Back of Block. Right side and left side may extend forward to cover foot box if necessary.	
F.	31"	22"
G.	52"	42"
H.	18"	12" Vert. Opening
I.	68" bottom, 66" top – 61"	
J.	52"	44"
K.	56"	41"
L.	TIRES MAXIMUM 1" INSIDE OF BOTH BODY SIDES.	
M.	DRIVER'S COMPARTMENT MUST BE TOTALLY SEALED FROM ENGINE AND RACETRACK.	
N.	8" MIN / WITHIN 2" FROM 90° ANGLE *SOLID PANEL	
O.	20"	16" FROM GROUND TO CENTER OF BUMPER
X.	MUST HAVE GRADUAL SLOPE FROM ROOF TO THIS POINT	
Y.	6" MAX INTERIOR SLOPE FRONT TO REAR. SEE "Z" ON CAR DIAGRAM.	
Z.	MAXIMUM BODY RAKE IS 6" FRONT TO REAR AND BOTH SIDES OF BODY MUST NOT HAVE ANY MORE THAN 1.250 GAP IN THE CENTER OF THE BODY WHEN A STRING LINE IS USED FROM FRONT TO REAR.	

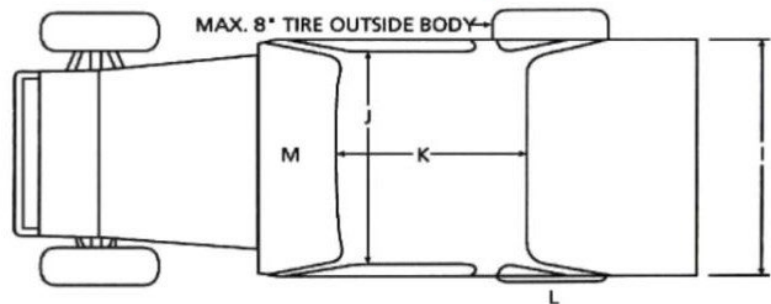
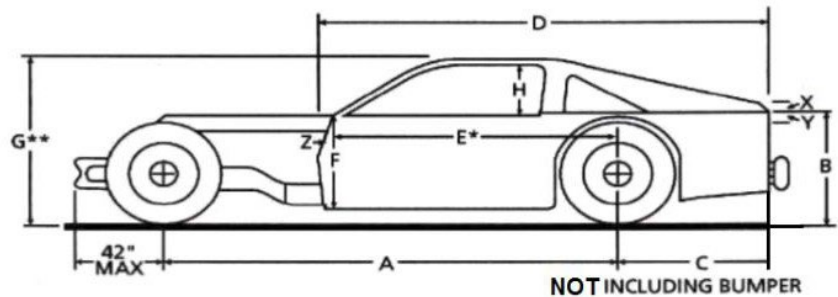
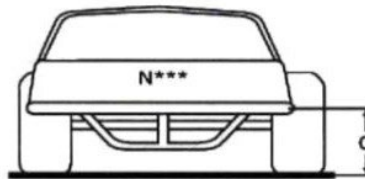

\*\* Using a level or straight edge, must have between ½" and 2" clearance at rear of roof, ½" to 5" at front

\*\* Maximum A post from front of the door to back of post is 19."

\*\* Maximum nose width is 45.5," flat and flush with side



## *High Banks Speedway 2027*

### **Body Mounting:**

The Preceding picture and definition will be used as a general guide for the purposes of determining legality of the body. Doors and quarter panels must be parallel from side to side, with no tapering from the front to rear allowed.

Sail panels must be the same on both sides of the body and in the same location (plus or minus 2 inches)

Maximum Bow – 4 inches

### **CAR, BODY, SPOILERS, & BUMPERS**

Tar and 5-star racing type bodies with windows are allowed.

Firewall is mandatory. Minimum 0.125-inch aluminum, or 16-gauge or 0.060-inch steel, complete floor required. Body parts may be constructed of steel, aluminum, or fiberglass only, no carbon fiber.

Wickers (airflow): 1" tall on the nose and roof only. No wicker on top of any type of body roll. (Like a 5-star nose).

Rear Spoiler – Allowed 4" tall, top 3" clear plastic cannot be wider than rear body. 240 square inches max. 3 inches tall spoilers can be over 60 inches wide, but not wider than the rear body or over 240 sq. inches. You may have an end cap on each side and a support in the center going forward, but it must be 12 inches from the end cap and cannot be longer than 10 inches and must taper down from the top of the spoiler to zero. The maximum wicker on the back side of spoiler is 1 inch. No wicker in the driver area or inside of the race car.

Engine compartment will remain open, with no side panels; hood sides may have maximum 5-inch drop and must be enclosed at rear of hood; maximum hood scoop height, 6 inches.

No pans or air deflectors allowed under body or chassis Both sides of the body may not have any more than 1.250 gap in the center of the body when a string line is used from front to rear. The passenger side of body must be no further forward than rear of block. Rear of bodies to be solid panel at least 8 inches high, within two inches of 90 degrees. No panel in front of the right door to engine compartment. No inner panels or inner fender well allowed.

Sail panels must closely resemble examples shown on body diagram, be the same on both sides of car and be straight. Reinforcing lips on rear of sail panels must be 180-degree bends.

The body may not go past the rear bumper or spoiler. The front nose may go past the front bumper 3 inches.

You can have a 2-inch step in the door panel (body line) no higher than the center line of the wheelbase. (Center of front hub or rear axle).

Driver and passenger side windows must have at least 12-inch opening, the same opening both sides, measured at center of window, between the lowest point at the top of window, whether the roof or roll cage, and the highest point at the bottom of window, whether the interior or body.



## *High Banks Speedway 2027*

Stock appearing front windshield and rear window support unit, painted roll bars not acceptable substitute.

May utilize a full windshield, with no wings, mounted to the roll cage. Must have a minimum of three windshield bars in front of driver. The cowl panel in front of the driver can be no wider than cockpit and no farther back than the steering wheel.

Steel bumpers must be used both front and rear at all times and must be 18 inches, plus or minus 2 inches from ground and securely mounted with minimum 0.375- inch bolts, made of minimum 1.25-inch OD tubing, 0.065" wall thickness on front, 0.095" wall thickness on rear, and must be able to support car if lifted by wrecker. Two bar front bumpers must be mounted frame-end to frame-end, no wider than the width of material outside frame horns, with the bottom loop parallel to the ground. Top bar must be directly above bottom bar, minimum 6½ inches apart, measured center to center at front of bumper (see P in body diagram), so bumper is perpendicular to ground.

Rear bumper, steel nerf bars and bodies must not extend beyond width of tires and must not contain any sharp edges. Rear bumper no more than 2 inches wider than body on each side. Fuel cells must be protected from bumper down to bottom of cell.

Nerf Bars: All cars must be equipped with approved side rail bars and scrub rails constructed of .083-inch minimum magnetic steel, seamless tubing with an outside minimum diameter of 1 inch. Must be full length from front to rear with minimum tire clearance. Side rail bars must be center lined with the front and rear axles. Only 2 intermediate supports per bar will be permitted. Side rail bars and scrub rails must be fastened to the frame. Side rail bars and scrub rails must not extend past the outside edge of the rear tires and taper slightly toward the front tires. Rear quarter-panel side rail bars, right side will be no wider than 4 inches to the outside of the side rail. Both sides will be no wider than the outside of the left rear tire.

Body to be mounted parallel to the chassis and will be measured on the left side of the car.

### **WINDSHIELD, GLASS, AND MIRRORS**

Front and rear Lexan windshields are recommended.

No colored/tinted Lexan, decals, or graphics allowed on front or rear windshield areas.

3 - 5/16" steel bars evenly spaced and securely mounted in front of driver are required.

Rear view mirror with a maximum width of 26 inches will be permitted.

Front edge of roof or windshield is reserved for series sponsor decal. This is mandatory to receive points.



## *High Banks Speedway 2027*

### **FRAMES**

1970 or newer, American made, passenger car frames only.

Frame may be cut in rear only at a point not further than 36 inches from center of rear-end housing.

Frame may not be widened or narrowed, must be full and complete on both sides.

Front cross member may be notched for radiator clearance only.

### **ROLL BARS**

All cars must have a steel roll cage consisting of continuous hoop not less than 1-3/4 inch outside diameter and must have a wall thickness of at least .095.

Cage must be mounted in at least six places with proper bracing to protect the driver.

Earnhardt bar is recommended; a vertical support downtube from upper halo to cage to add support to upper halo.

Minimum of three driver side door bars, parallel to the ground and perpendicular to the driver and welded to front and rear of roll cage.

Bar across back of engine with vertical rub rails for protection of feet is required.

Steel door plates must be securely welded to outside of driver side door bars and cover area from top door bar to bottom door bar and from rear hoop down-post to five inches in front of seat.

No brace bars forward of cage may be higher than stock hood.

Down bars cannot pass through the hood.

### **ENGINE SPECIFICATIONS**

High Banks Speedway uses an open Engine Rule. A GM LS Engine is allowed with a flat timing curve crank trigger ignition. All engines must start under their own power. No aluminum blocks. No V-6 engines.

No dry sump oil systems.

Engine must be at least 72 inches from the back of the block to the center of the rear end housing.

A maximum of 2 inch offset allowed.



## *High Banks Speedway 2027*

### **EXHAUST**

Mufflers are mandatory - 95 DBA OR LESS WILL BE STRICTLY ENFORCED!

Exhaust must extend under the car and behind the driver and be securely mounted.

Heat shields to cover exhaust system can be no more than 4 inches wide and no longer than the valve covers.

### **CARBURETOR**

High Banks Speedway uses an open carburetor rule. See general rules for air filter requirements.

### **IGNITION**

Only a point type, single or dual, or electronic system is permitted.

No magnetos or computerized systems are allowed.

The distributor must mount in the stock location and maintain the same firing order as a factory produced engine for the make and model engine being used.

Crank trigger ignition system allowed on GM LS only but must maintain a flat timing curve.

No adjustable timing controls allowed.

No ignition system equipment or wiring may be located in the driver's side door area.

All ignition system equipment must be securely mounted, with an unobstructed view, and to the driver's right.

All wires from MSD to distributor must be visible with NO open connections.

Cell phones, smart watches, and / or Bluetooth devices will not be allowed in the racecar at any time during qualifying or race.

### **COOLING SYSTEM**

Cooling system may be modified.

Radiator and oil coolers must not protrude above interior.

Minimum 2-quart catch can, must be securely mounted.



## *High Banks Speedway 2027*

### **TRANSMISSION**

No 5 speed transmissions or “in and out” boxes allowed.

Automatic transmissions are allowed.

No transmission gear may be closer than 1.23:1 of the final drive ratio of 1:1.

Internal clutch transmissions are allowed – such as Bert and Brinn.

### **CLUTCHES**

Aluminum or light alloy clutch assemblies are allowed.

No carbon or carbon fiber clutches are allowed.

### **DRIVE SHAFTS**

No aluminum or carbon fiber drive shafts, yolks, or slip yolks allowed.

Driveshaft must have a 360-degree drive shaft loop and must be constructed of at least (1) 0.25 inch by two-inch steel, or one inch tubing, mounted six inches back from front U-Joint preventing the shaft from being dislodged and dropping onto the racing surface.

### **REAR END**

Any passenger car or truck type rear-end is permitted.

Quick change rear ends are allowed provided steel tubes and mounts are used.

Full spool, mini spool or welded rear ends only.

No open or unlocked rear ends.

Aluminum lowering blocks, axle caps, and drive plates are allowed.

No cambered rear-ends or titanium axles or lower shafts are allowed.

No rear sway bars are allowed.

Locking devices like Gold Tracs are NOT allowed.

Final drive ratio must be a maximum of 6:20.



## *High Banks Speedway 2027*

### **BRAKES**

Working calipers or drums on all four wheels is required.

OEM type brake parts only.

No carbon fiber. No titanium.

No aluminum calipers.

No aluminum components.

Rotors cannot be lightened or drilled. Must be OEM or OEM replacement; minimum width .800 for front brakes 11" diameter.

No solid-type rotors allowed.

Racing type brake pedals and master cylinders permitted.

Brake bias adjustments or adjuster valves are permitted.

Two-piece steel rotors and hubs are permitted as long as they are not drilled.

### **TREAD WIDTH**

81 inches maximum, measured from the outer most part of the tire at spindle height, zero tow in, front and rear *as* presented for inspection –No tolerance. Must fit High Banks Speedway gauges.

### **WHEEL BASE**

108 inch minimum



## *High Banks Speedway 2027*

### **SUSPENSION**

Must be unaltered OEM stock replacement in stock location and must be replaceable by stock parts from same type. Fabricated front stubs are not allowed.

Lower A-frames cannot be moved.

Tube type steel upper A-frames permitted.

Aluminum cross shafts permitted. IMCA approved aluminum coil over kit is permitted for the rear. Heim joints and steel sleeves and mono balls will be permitted on the front suspension provided the component is not modified to accommodate use.

Hubs and A-frames cannot be made of aluminum; any other aluminum suspension parts are also not allowed.

No fiberglass suspension parts allowed.

Any type of front sway bar is optional.

No weight changing devices to be mounted so that they may be operated from inside of the car.

Ford strut cars may thread or modify frame end of strut. Bearing mounted strut is allowed.

Any ball joint will be allowed.

### **SPINDLES**

Stock passenger car spindles only. No welding, grinding, bending, fabrication of spindles allowed.

Aluminum spindles not allowed.

No drop spindles.

### **STEERING**

Steering box must remain within one original bolt pattern for type of frame used.

No rack & pinion steering.



## *High Banks Speedway 2027*

### **SHOCKS / SPRINGS**

Only shocks allowed are one steel, nonadjustable, unaltered shock per wheel. No threaded body shocks, front or rear, or air type, or remote reservoir shocks. Shocks cannot be mounted in the center of spring. If the shock utilizes an external gas port; the only legal gas port is a Schrader valve style. Gas plugs that do not allow the shock to be degassed without removal of the plug, and gas ports that utilize needle filling systems, are not allowed. Internal, stationary base valves, meant to reduce gas pre-load, are not allowed. \*The steel body of the shock must be the same diameter top to bottom, except for Penske 7100/7150 series, Advance 7200 series, Ohlin's CCI-8, JRI SL/10, or SL/14 and Bilstein SNS2 series are approved. Aluminum caps are allowed. Bump Stops may be applied to shock absorber shaft to limit travel. Bump Stop styles allowed are Foam, Polyurethane, Rubber, Spring, Belleville Washer. NO COMPRESSED AIR STYLE BUMP STOPS.

No cockpit adjustments allowed other than one brake bias. No air shocks or air bags allowed. No torsion bars or air bags.

Only one steel spring per corner allowed, Minimum 4½ inches non-progressive coil spring and/or steel leaf spring per wheel.

No torsion bars in rear allowed.

Bump Stops and Bump Springs are allowed.

A 3<sup>rd</sup> link spring bar with minimum 5" spring allowed; must be all steel.  
Biscuit Bar on right side trailing arm allowed; must be all steel.

### **WHEELS & TIRES**

8.0 inch steel approved racing wheels are mandatory.

Mandatory track tire will be a Hoosier 970 series tires.

All tires must be purchased at High Banks Speedway and will be marked, if a driver is found to be using tires that have not been marked, they will be automatically disqualified for the evening with a minimum loss of points and prize money.

All competitors are allowed to purchase up to 5 new tires (2 right side and 2 left side and 1 spare) and must run those four tires for BOTH qualifying and competition (Dash & Feature Races) for three consecutive nights of racing. You are permitted to put your 5<sup>th</sup> tire on when you see fit, this 5<sup>th</sup> tire MUST be used in cycle with other 4 tires.

Tire rules subject to change upon level of competition per High Banks Speedway Official's discretion.

Wheel adapters made of steel or billet aluminum are allowed, up to 2 inches on rear only.

No cast aluminum adapters allowed.



## *High Banks Speedway 2027*

### **WEIGHT: *Weight must be posted on the Passenger A-Pillar!***

All cars prior to a race shall weigh no less than 2575 pounds and no more than 58% left side weight. This includes engine requirement weight penalty if applicable.

Weight rules are subject to change per level of competition at High Banks Speedway Officials discretion.

All cars must be able to cross over the scales without any part of the frame or body touching the scale or ramps. You will not be allowed on track if it hits. If a car is deemed to repeatedly contact the racing surface it will be black flagged with the corresponding finish.

All ballast must be lead and painted white, and car numbers must be identified on all lead including in lead rail.

602 crate motor option: weight is 2,500lbs.

### **FUEL**

Only racing fuel will be permitted and must be purchased from High Banks Speedway directly.

Alcohol will be allowed provided a minimum of a six-inch letter "A" is affixed at the rear of the side door numbers for emergency crew identification.

Racing fuel shall not be blended with any other gasoline or any additives, nitro compounds, or other oxygen containing compounds. It is the competitor's responsibility to ensure that fuels are not mixed in previously used containers.

Icing or cooling of fuel system will not be permitted in the pit or racing areas.

Icing, Freon type chemicals, or refrigerants may not be used in or near the fuel system.

Pressure systems will not be permitted.

Any concealed pressure type containers, feed lines, or actuating mechanisms will not be permitted, even if inoperable.

Only 1 gasoline filter may be used between the fuel cell and the fuel pump. The location and size of the filter must be acceptable to High Banks Speedway officials.

No nitrous oxide or additives of any kind allowed.



## *High Banks Speedway 2027*

### **FUEL CELL**

The use of a racing fuel cell is required and must be mounted by at least two steel straps 2 inches wide around the cell.

Fuel cells must be enclosed in metal container and must also be protected in rear with roll-cage tubing and securely mounted behind the rear-end.

Fuel cell height 9 inches minimum measured to bottom of cell from ground with driver inside. No part of fuel cell should be lower than protective tubing.

Fuel cells must be vented out upper left rear corner with a flapper or check valve in the vent tube. No glass or plastic fuel filters are allowed.

A reinforcement plate of not less than 1/8 inch magnetic steel must be installed behind the fuel cell. Plate must be welded to cage and must extend the entire width and height of the fuel cell.

Steel braided fuel lines or lines sealed in pipe or conduit are required.

Oberg or SRI antisiphon valve is mandatory; mounted near fuel cell after fuel filter.

### **OUT OF TOWN CARS**

High Banks Speedway invites all Out-of-Town competitors. Due to differing levels of competition, High Banks Speedway reserves the right to adjust gear, total weight, or bias on an individual basis.

Adding weight, requiring the loss of left side percentage, or requiring a carburetor restriction plate on a vehicle, will be tools used by High Banks Speedway officials to maintain fair competition. It is the responsibility of each competitor to read and understand the contents of these Rules. If there is a disagreement or dispute regarding the meaning or application of these Rules, the decision of the Track Steward will prevail.

\*\*\* Please refer to General Section for rules and regulations applicable to all divisions\*\*\*